

Measurement of the neutrino
mixing angle θ_{13} with the
Double-CH $\theta_{13}\theta_{13}$ Z experiment

Thierry Lasserre (CEA/Saclay & APC)
On behalf the Double-Chooz proto-collaboration

NOON04 Workshop, Tokyo
February 12 2004

Best current constraint: CHOOZ

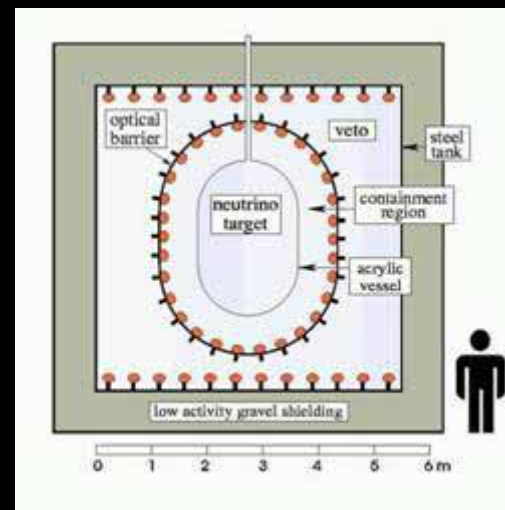
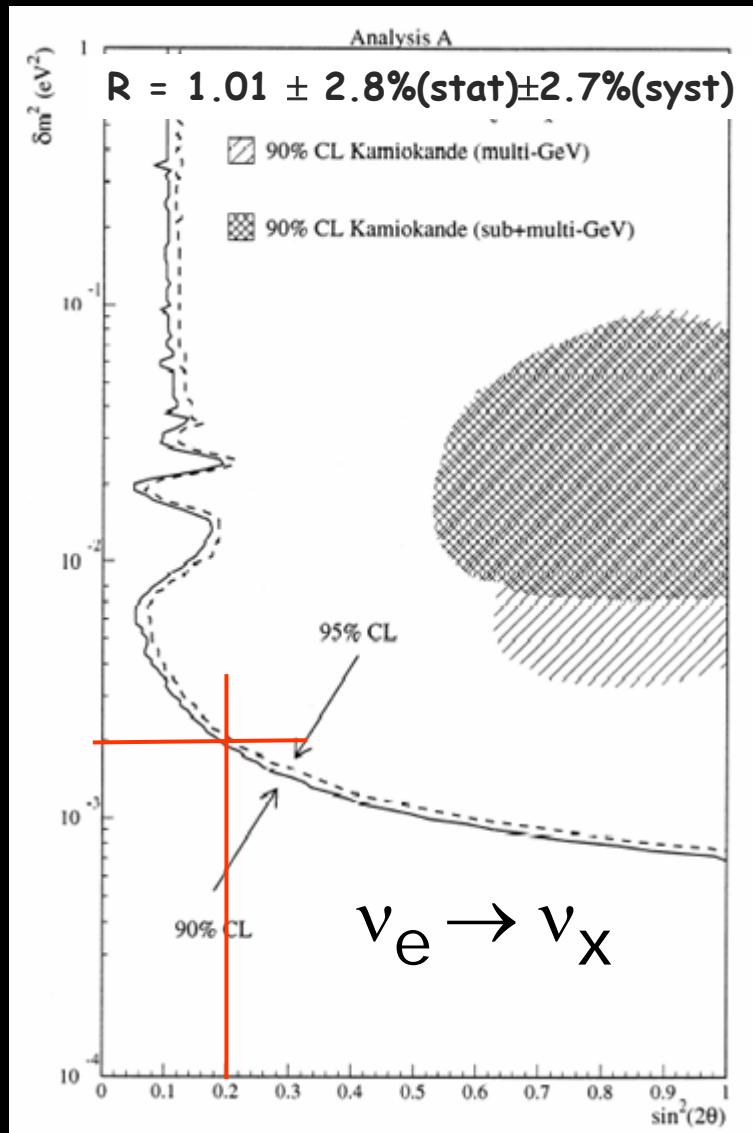

World best constraint !

@ $\Delta m^2_{atm} = 2 \cdot 10^{-3} \text{ eV}^2$

$\sin^2 2\theta_{13} < 0.2$

(90% C.L)

The Chooz site



2x12.5 tons, D1=100-200m, D2=1050m. Sensitivity: 3 years $\rightarrow \sin^2(2\theta_{13}) < \sim 0.03$

CHOOZ-Far... ready to be used again!



Photo taken in September 2003

CHOOZ-Far detector

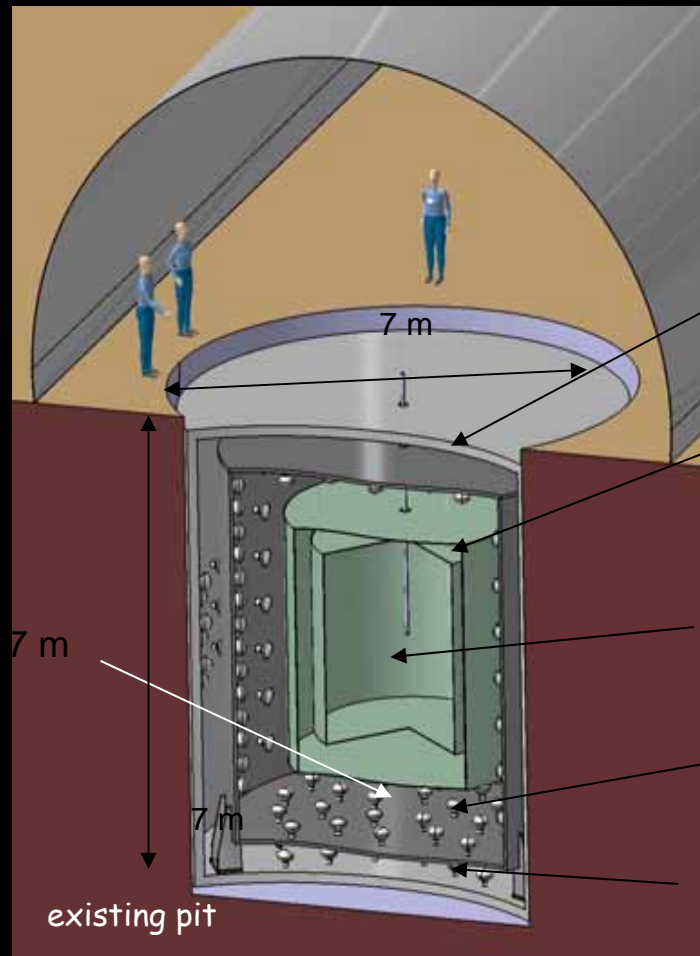

Shielding : main tank of 0.15m of steel

Gamma catcher inside Acrylic Vessel
Thickness : 0.6m

Target cylinder ($\phi = 2.4\text{m}$, $h = 2.8\text{m}$) filled
with 0.1%Gd loaded liquid scintillator (12.7
Tons)

Buffer inside non-transparent vessel
equipped with PMTs

Muon VETO of scintillating oil
Thickness : 0.6 m

(12.7m³ fiducial volume)

CHOOZ-Near

Near detector @100-200 m from the nuclear cores
in discussion with EDF



CHOOZ-Near new Laboratory

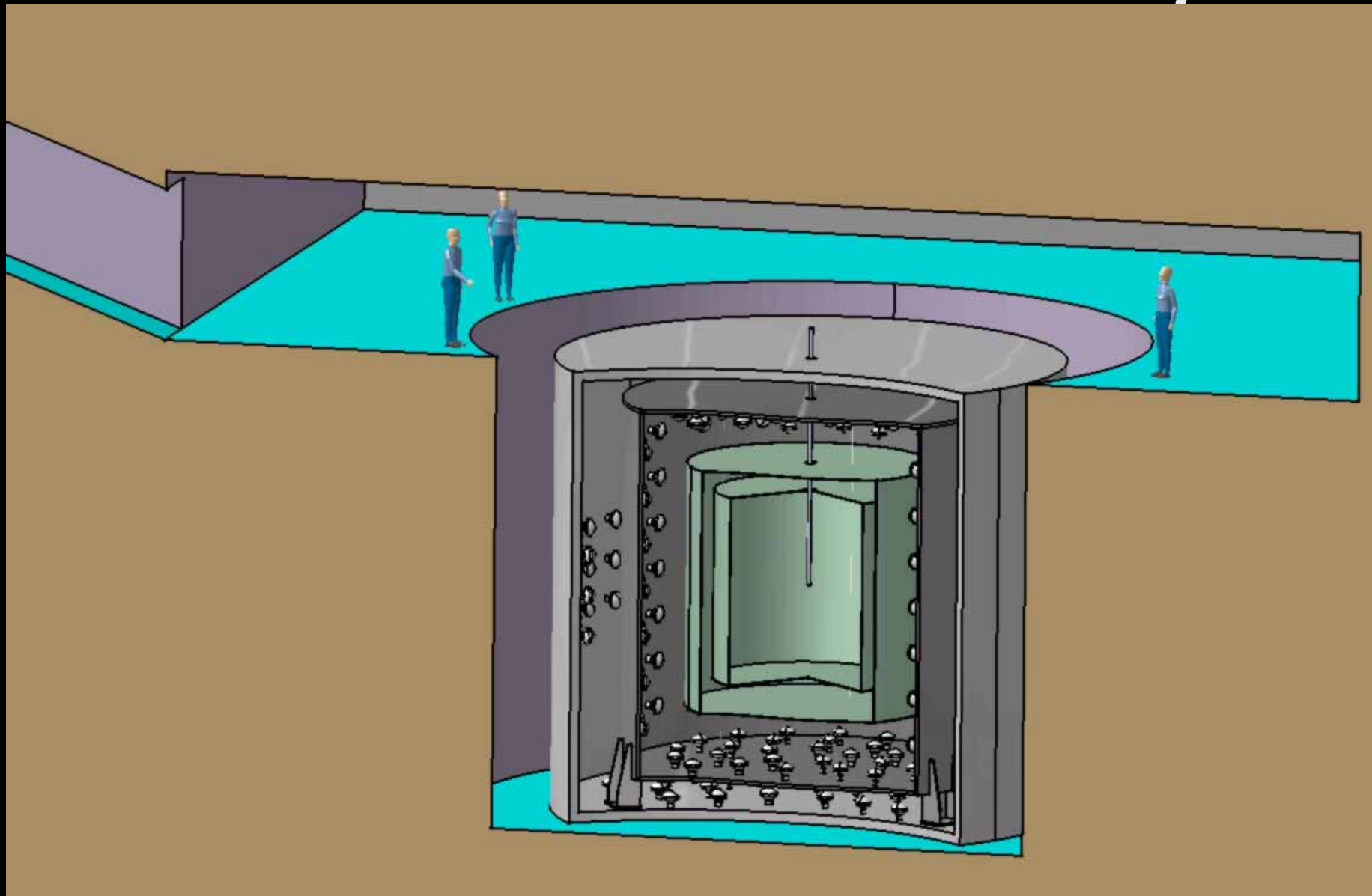

Other possibility: bloc of concrete ($d \sim 2.4$) piled up !

Status of the discussions with EDF

- ✓ **CHOOZ site has been secured.**
 - Strong support for the CHOOZ nuclear plant
- ✓ **Far site: 1.1 km & 300 mwe**
 - Existing laboratory
 - Available (7x7 m tank of CHOOZ-I)
- ✓ **Near site: 100-200 m**
 - Underground detector + man-made overburden
 - Feasibility confirmed by the power plant staff
 - 50 to 70 mwe required
 - Preliminary civil engineering study proceeding ...

Improve CHOOZ is difficult - Statistics -

@CHOOZ: $R = 1.01 \pm 2.8\%(\text{stat}) \pm 2.7\%(\text{syst})$

✓ Increase the luminosity $L = \Delta t \times P(\text{GW}) \times V_{\text{target}}$

• Detector size : CHOOZ = 5 t → Double-Chooz = 12.5 t

• Data taking time (3 ans → 5 ans) with high efficiency

• CHOOZ : 2700 events → $\sigma_{\text{stat}} = 2.7 \%$

Double-Chooz 60 000 evts → $\sigma_{\text{stat}} 0.4 \%$

@1.05 km, 60 keVts $\approx 12,3 \text{ tons} \times 8.4 \text{ GWth} \times 3 \text{ years}$

12.7 t PXE+80%dodecane ~9 10 ²⁹ free H	100 m	200 m	1050 m
ν Flux day ⁻¹ · no osc.	9771	2442	88
ν Flux year ⁻¹ · no osc.	3.6 10 ⁶	0.9 10 ⁶	32350

100% efficiency

By product → high accuracy neutrino physics with the near detector

Improve CHOOZ is difficult - systematics -

✓ Decrease systematic errors

- Systematic errors for CHOOZ : $\sigma_{\text{sys}} \sim 2.8\%$
- 1) Improve the detector design for θ_{13} measurement
- 2) 2 identical detectors \rightarrow towards $\sigma_{\text{relative sys}} \sim O(0.1\%)$
- Strategy: gain a factor /10 to get $\sigma_{\text{rel [detector1-detector2]}} < 0.8\%$
- Backgrounds: $S/N > 100 \rightarrow$ error $< 1\%$

Reactor induced systematics

2 detectors → cancellation of the reactor physical uncertainties

systematics	Error type	CHOOZ	Future Experiment	2 identical detector Low background
Reactor	Flux, cross section	1.9%	-	O(0.1%)
	Thermal power	0.7%	-	O(0.1%)
	E/Fission	0.6%	-	O(0.1%)
	Σ	2.1%	-	O(0.1%)

Detector induced systematics

systematics	Error type	CHOOZ	Future Experiment	Monte-Carlo	2 identical detector Low backgrounds
Detector	Scintillator density	0.3%	0.3%		O(0.1%)
	% H	1.2%	1.2%		O(0.1%)
	Target volume	0.3%	0.2%		0.2%
	« Spill in/out » effect	1.0%	1.0%	X	O(0.1%)
	Live time	?	0.25%		0.25%

M. Apollonio et. al., Eur.Phys.J. C27 (2003) 331-374

A single scintillator batch will be prepared to fill both detectors with the same apparatus

Why two identical detectors ?

Anti- ν_e tag: $\bar{\nu}_e + p \rightarrow e^+ + n$, ~ 1.8 MeV Threshold

- Prompt e^+ , $E_p=1-8$ MeV, visible energy
 - Delayed neutron capture on Gd, $E_D=8$ MeV
 - Prompt(β/γ) - Delayed(β/γ) \rightarrow pulse shape discrimination
- Time correlation: $\tau \sim 30\mu\text{sec}$
 Space correlation: $< 1\text{m}^3$

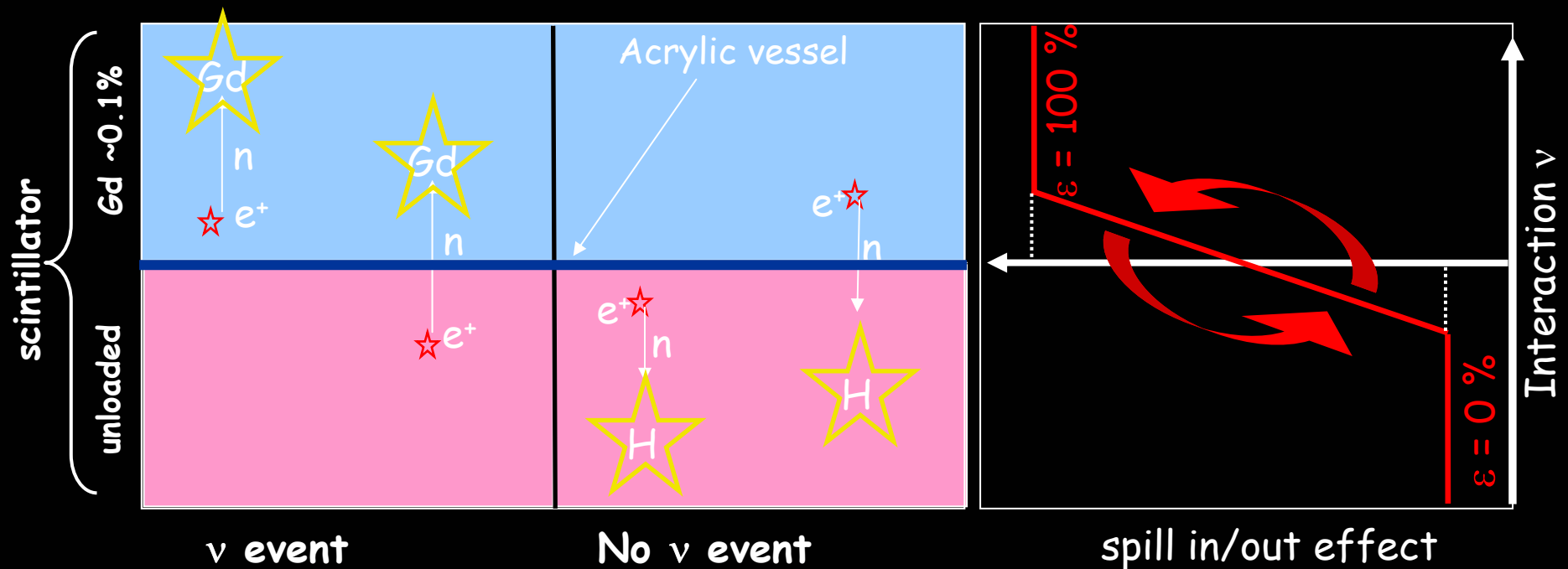

Relative Normalisation: detector

✓ Solid angle

- distance measured @10cm
- To confirm ...

✓ Target volume

- @CHOOZ : 0.3% [simple measurement]
- Goal ~0.2% [same apparatus for both detectors] - Not trivial ...

✓ Density

- 0.1% achievable
- Accurate temperature control mandatory

✓ H/C & Gd concentration

- Absolute measurement is difficult : 1% error @CHOOZ
- Plan: use the same batch to fill both detectors

✓ Edge effect (spill in/out)

- Neutronic slightly different due to solid angle effect
- MC study to be done to check that it is negligible

✓ Live time to be measured accurately by several orthogonal methods

Relative Normalisation: Analysis

✓ @CHOOZ:

- 7 analysis cuts
- Efficiency ~70% & 1.5% systematic

Sélection cuts

- | | |
|----------------------------|----------------------------------|
| - positron energy | [energy threshold] |
| - e+ position/géode (30cm) | [position reconstruction] |
| - neutron energy | [energy cut - calibration] |
| - n pos./géode (30 cm) | [position reconstruction] |
| - distance e+ - n | [position reconstruction] |
| - Δt e+ - n | [neutron capture on Gd] |
| - n multiplicity | [level of accidental background] |

✓ Goal Double-CHOOZ

- 2 to 3 analysis cut

Sélection cuts

- | | |
|---|------------------------|
| - neutron energy
(- distance e+ - n) | [level of accidentals] |
| - Δt e+ - n | |

ν selection systematics @Chooz

Error type	CHOOZ
Ee+ threshold	0.8%
e+ position/géode (30cm)	0.1%
n capture	1.0%
En	0.4%
n pos./géode (30 cm)	0.1%
Distance (e+-n)	0.3%
Δt (e+-n)	0.4%
n multiplicity	0.5%
Σ	1.5%

M. Apollonio et. al., Eur.Phys.J. C27 (2003) 331-374

ν selection systematics @Double- Chooz

Cuts
$6 < E_n \text{ (MeV)} < 12$
$2 < \Delta n < 100 \mu\text{s}$

Error type	CHOOZ	Future Experiment	Monte Carlo	2 detectors Low background
n capture	1.0%	$< 1.0\%$	X	$O(0.1\%)$
En	0.4%	$\approx 0.4\%$		0.2% calibration
Δt (e+-n)	0.4%	$< 0.3\%$	X	0.2%
Σ	-	$< 1.1\%$		$< 0.3\%$

Prompt e^+ & Scintillating buffer

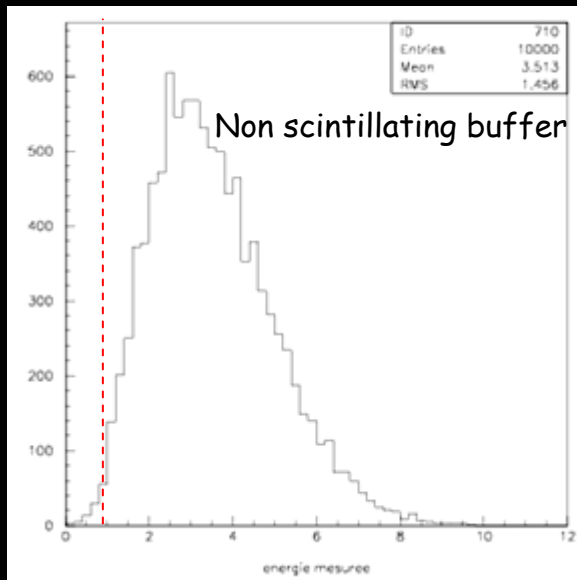

E_{e^+} (MeV)

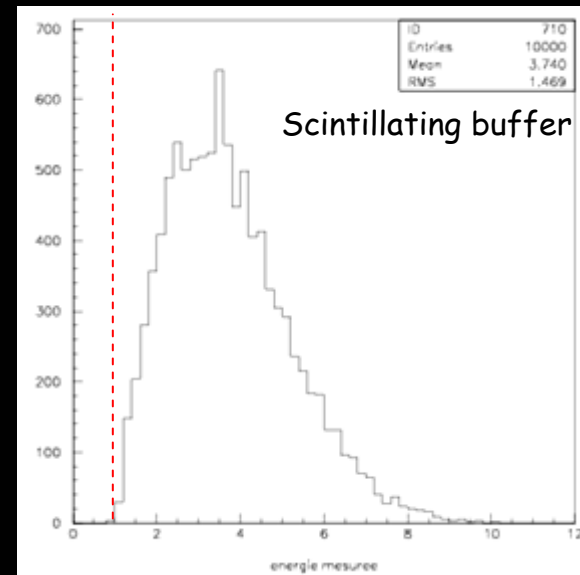

(H. de Kerret)

E_{e^+} (MeV)

- **Scintillating buffer:**

- The positron energy is fully contained
- $E_{\text{threshold}} < E_{\text{min}}(e^+) \rightarrow$ No threshold effect \rightarrow 0% systematic! (0.8 % dans CHOOZ)
- Relative calibration point between the two detectors
- Background measurement at low energy (threshold foreseen \sim 500 keV)

But more accidental backgrounds due to PMT radioactives content (^{40}K)
 \rightarrow A third region (non scintillating) is needed to keep the acc. backgrounds low

Delayed n & Scintillating buffer

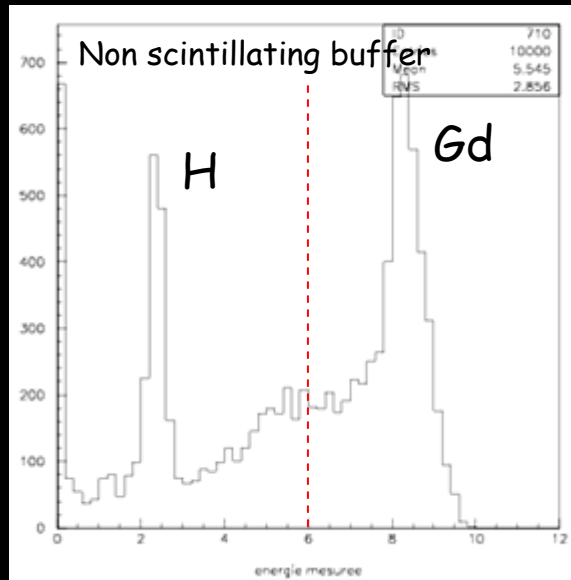

E_n (MeV)

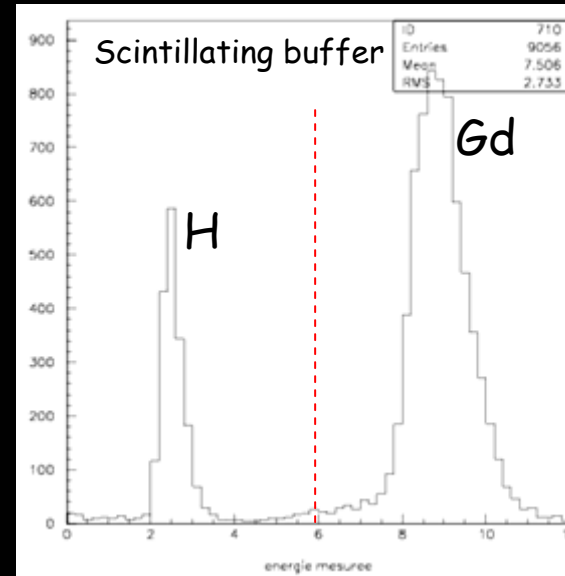

(H. de Kerret)

E_n (MeV)

✓ Gadolinium loaded scintillator (~0.1%)

- $Gd \rightarrow 8 \text{ MeV } \gamma$'s (capture on Gd : $86.6\% \pm 1.0\%$ in CHOOZ, Eur.Phys.J. C27 (2003) 331-374)
- $H \rightarrow 2.2 \text{ MeV } \gamma$'s
- n capture prob. $\pm 1.0\%$ (CHOOZ) $\rightarrow 0\%$ with 2 detectors (MC uncertainty)
- Δt ($e^+ - n$) $\rightarrow \pm 0.4\%$ (CHOOZ) $\rightarrow 0\%$ with 2 detectors (MC uncertainty)

✓ n energy $\rightarrow \pm 0.4\%$ (CHOOZ) \rightarrow Scintillating buffer mandatory (as in CHOOZ)

✓ "spill in / spill out" effect $\rightarrow \pm 1.0\%$ (CHOOZ) \rightarrow $O(0.1\%)$ 2 identical detectors needed!
 \rightarrow But neutronics to be checked

Systematics: summary

✓ Goal Double-CHOOZ

- Spatial effect	Negligible - To confirm
- Target volume	0.1 - 0.2%
- density	0.1%
- H/C & [Gd]	0.2%
- Edge effects [neutronics]	2 nd order effect ? To confirm
- Analysis cuts	0.3%
- Live time	< 0.2%

	~ 0.5-0.6%

Full detector simulation

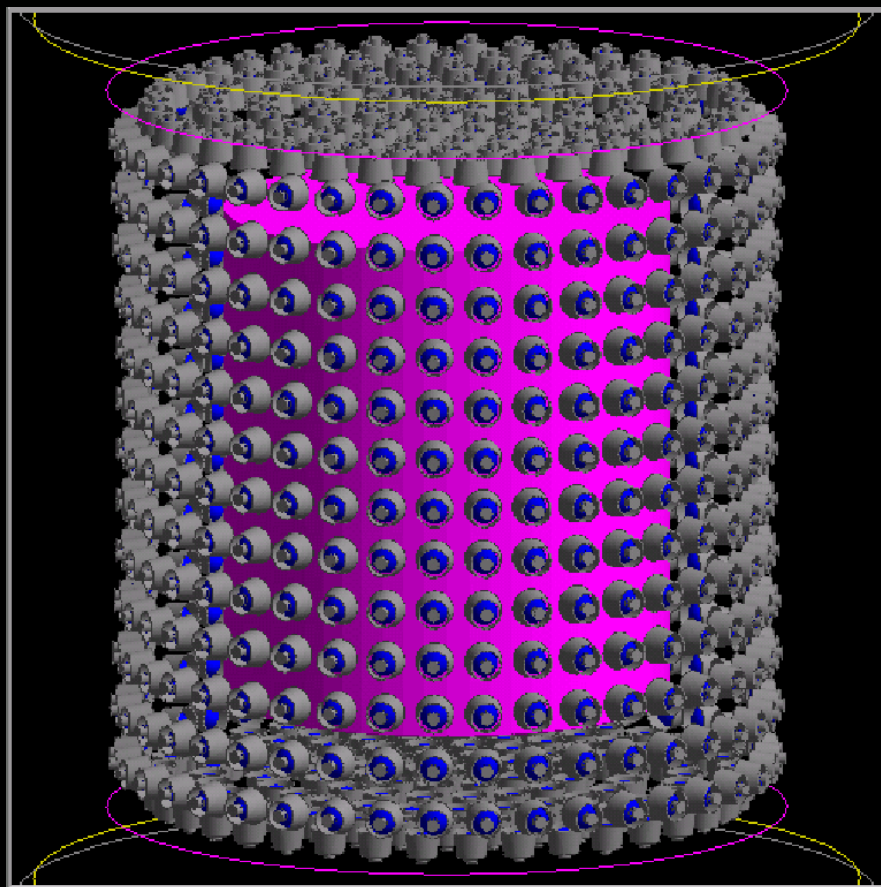

2 independent full detector simulations

- PCC & APC → Former Chooz simulation
- Kurchatov Institut → Borexino based simulation

MC → 763 PMT ⇒ $2 \cdot 128 + 507$ 17.5% Coverage

$507 = 13 \text{ rings} \cdot 39 \text{ PMT in each}$

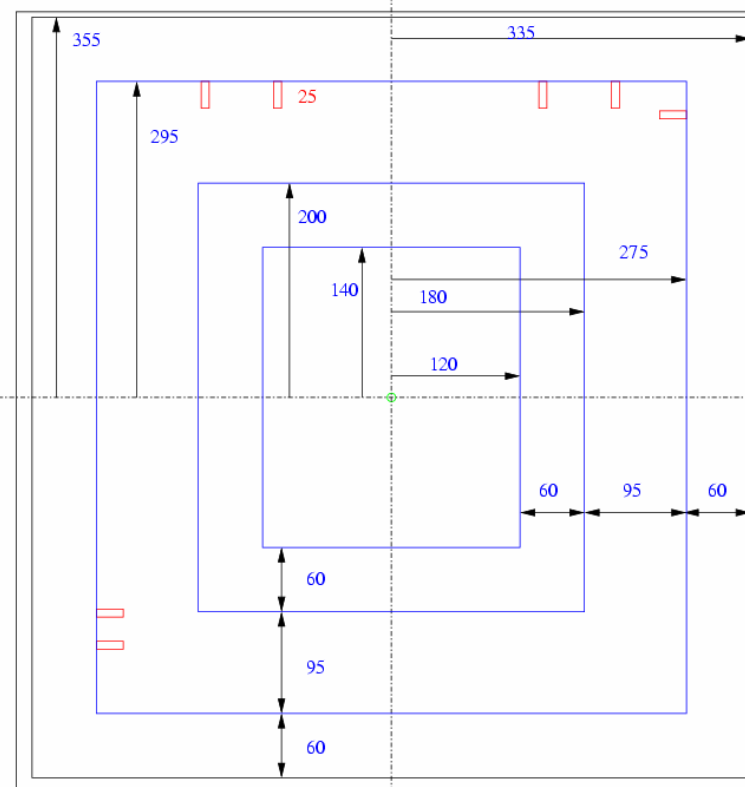

All sizes are in cm.

Full detector simulation (preliminary)

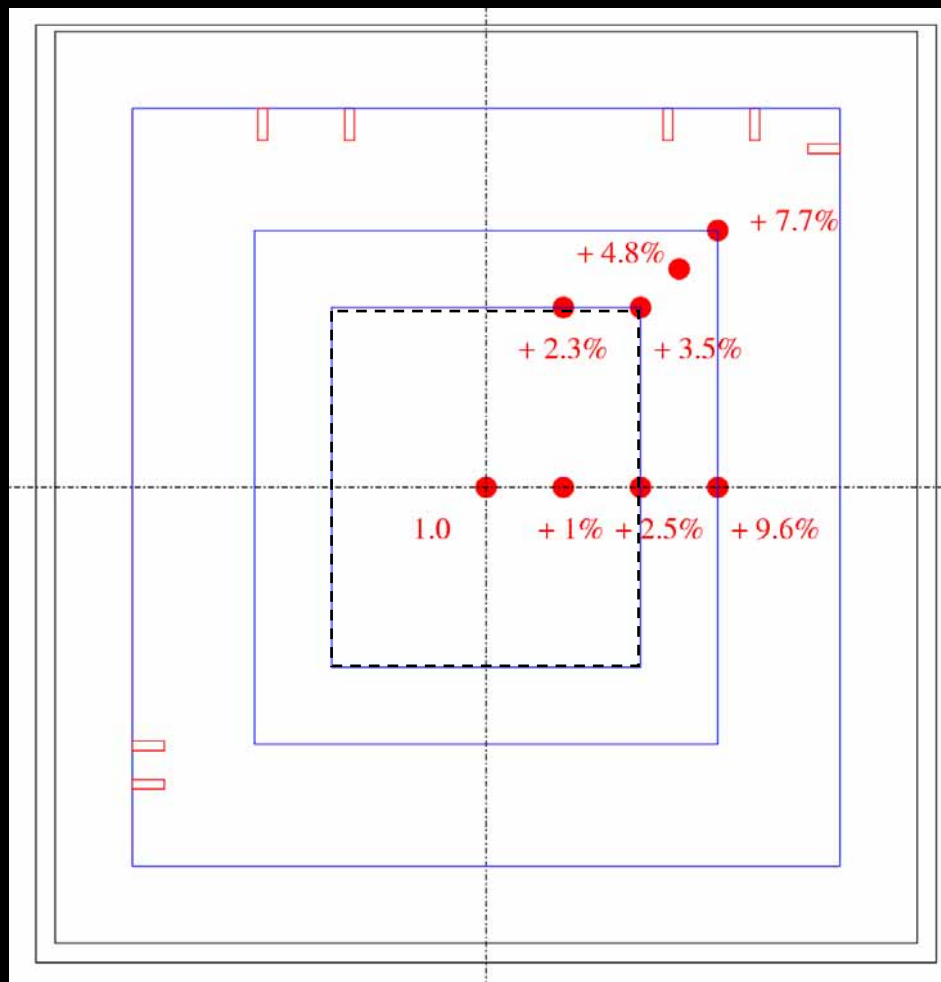

- PXE + mineral oil + 0.1% Gd + PPO + BisMSB
- 200 p.e./MeV with 500 PMTs - Reflectivity=0%
- PMTs are 25 cm inside the volume
- Light collection is very flat +5% at the target frontier

8000 photons K_Refl=0

X [cm]	Y [cm]	Z [cm]	Yield[%]
0	0	0	100
0	60	0	101,0
0	120	0	102,5
0	180	0	109,6
0	60	140	102,3
0	120	140	103,5
0	150	170	104,8
0	180	200	107,7

Backgrounds Estimates

- CHOOZ: N/S ~ 4%

- Double-CHOOZ-Far (300 mwe): 12.7 tons → Signal × 3

- Modification of the detector design → + expensive

- Uncorrelated events: Double-Chooz: S×3 & N/3 → < 0.5%

- Correlated events: N/S < 1%

CHOOZ : ~<1 recoil proton / day

Double-CHOOZ liquid active buffer : +30cm larger → ~0.3 events / day

- Double-CHOOZ-near (50 mwe): Signal × 50-100 S(CHOOZ-Far)

- Key advantage: $D_{near} \sim 100-200m \rightarrow$ Signal × 50-100 !

- Uncorrelated: CHOOZ-Far backgrounds × 50 → N/S < 1%

- Correlated events: CHOOZ-Far × <30 → N/S < 1%

(but not a comprehensive list of backgrounds ...)

Neutron Induced Background

- Simulation of the transport of μ induced neutrons (*Geant4*)
- Neutron production in the surrounding rock by cosmic ray muons and their transport simulated with **Fluka**
- Research of neutrino like events in the scint. target
- Ongoing work

Rock
Laboratory
Tank
Buffer
Gamma Catcher
Detector

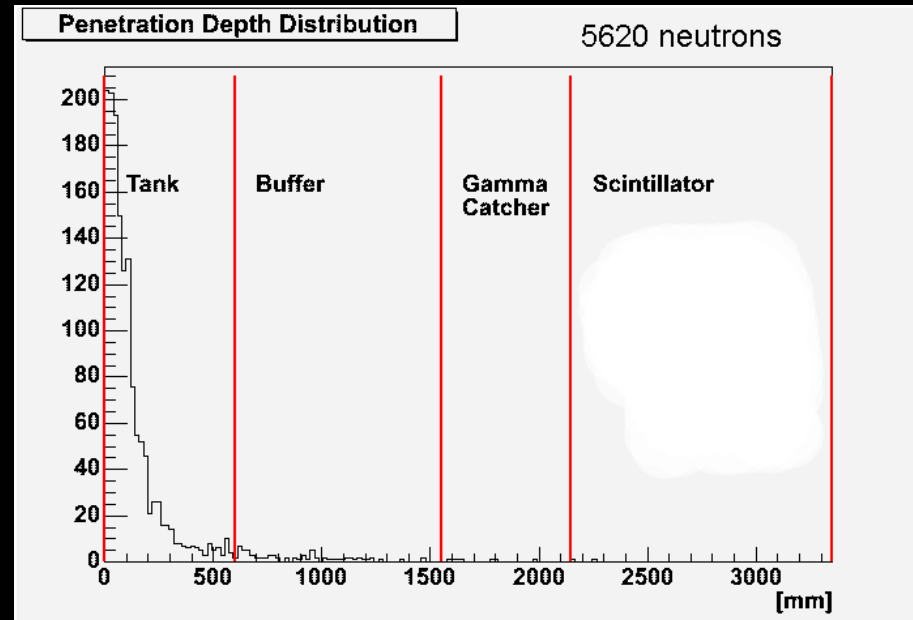
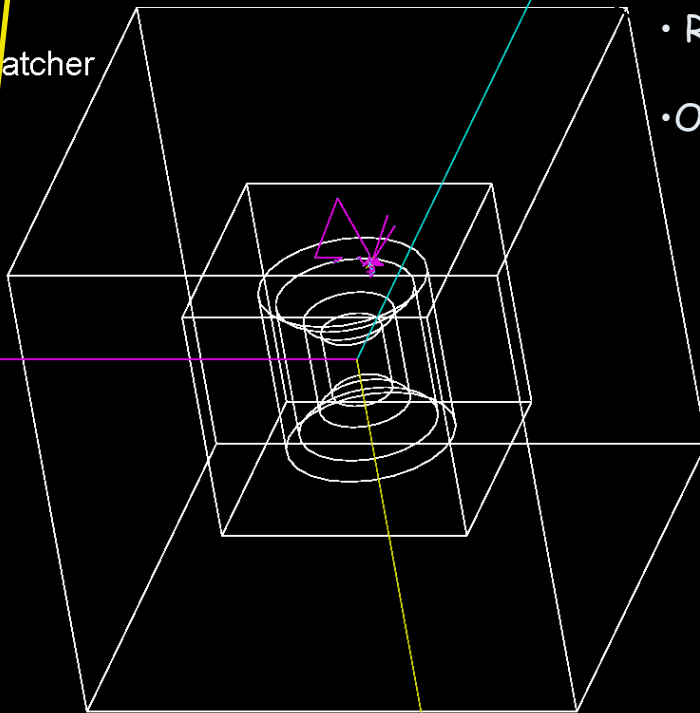

Preliminary

+ Background working group : internal + external bkg under study

Muon induced production of radioactive isotope

-Background: Production of radioactive nuclei on ^{12}C in the scintillator

-NA54: Isotope production on ^{12}C target @SPS/CERN, μ beam @100/190 GeV $\rightarrow \sigma(E) \propto E^{0.73}$ (T. Hagner et. al.)

	Isotope	$T_{1/2}$	E_{max} (MeV)	Rate (day^{-1}) 300 mwe	Rate (day^{-1}) 20 m (50 mwe)	Type
β^-	^{12}B	0.02 s	13.4	-	-	Uncorrelated
	^{11}Be	13.80 s	11.5	< 2	< 23	Uncorrelated
	^{11}Li	0.09 s	20.8	-	-	Correlated
	$^9\text{Li} +$ ^8He	0.18 s	13.6	2 ± 0.3	21 ± 4	Correlated
		0.12 s	10.6			Correlated
	^8Li	0.84 s	16.0	4 ± 1	39 ± 14	Uncorrelated
^6He	0.81 s	3.5	14 ± 1	155 ± 16	Uncorrelated	
β^+ , EC	^{11}C	20.38 m	0.96	770 ± 49	8765 ± 562	Uncorrelated
	^{10}C	19.30 s	1.9	98 ± 12	1118 ± 141	Uncorrelated
	^9C	0.13 s	16.0	4 ± 1	47 ± 15	Uncorrelated
	^8B	0.77 s	13.7	6 ± 1	69 ± 14	Uncorrelated
	^7Be	53.3 d	0.48	196 ± 20	2228 ± 223	Uncorrelated

• Rates are given for the CHOOZ 10 + PXE case ($\text{C}_{16}\text{H}_{18}$)

- Single Rate

Dominated by ^{11}C (β^+ , 20.38 minutes half-life, end point @ 0.96 MeV)

- Correlated events

Dominated by β -n cascade, $\tau \sim$ few 100ms ^8He , ^9Li , ^{11}Li (instable isotopes)

But *efficiency of those events after muon veto cut + analysis ? Measurable ?*

Gd Liquid scintillator: completion of the R&D!

- ✓ LENS R&D completed → new metal β -diketone molecule (MPIK)
- ✓ Stable: 0.1% Gd-Acac (few months)
- ✓ Baseline recipe ~80% mineral oil + ~20% PXE + Fluors + wavelength shifters
- ✓ LY ~ 60% pure PC, attenuation length > 5m
- ✓ Spare stable scintillator based on carboxylate chemistry (MPIK, INFN/LNGS)

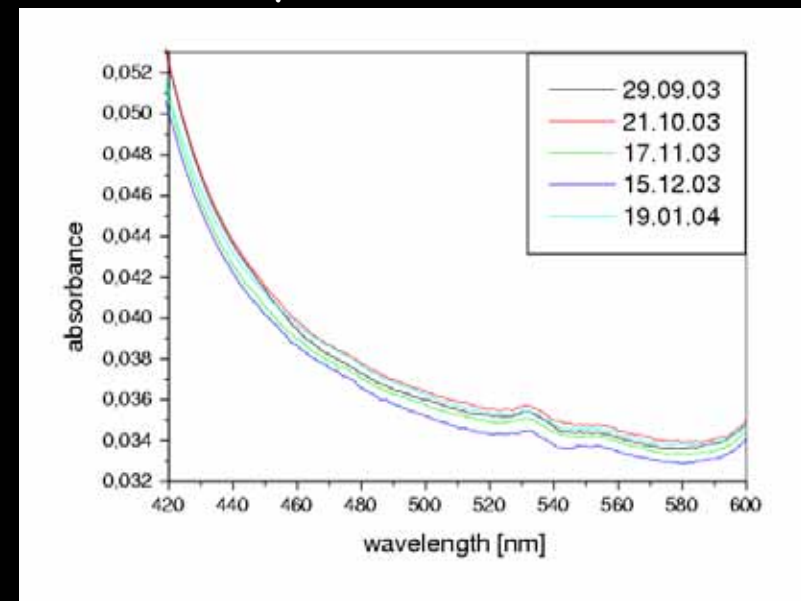
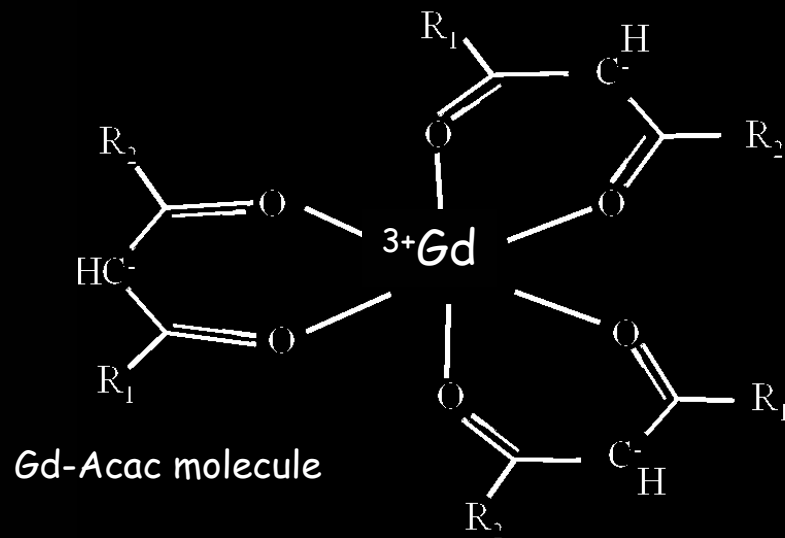

Stability 0,1 % Gd in PXE

- ✓ Completion of the R&D first half of 2004
 - ✓ Choice of the final scintillator
 - ✓ Stability & Material compatibility → Aging tests (MPIK, Saclay)

Gd Liquid scintillator & material compatibility

- ✓ Goal: 1/ Test the LONG term stability of the scintillator
2/ Test the material compatibility with acrylic, glue, ...
- Towards the design of the acrylic vessels
- ✓ Tight stainless steel boxes flushed with N_2 - 20- 130cl quartz cuvettes
- ✓ Aeging test → scintillator temperature ~50 degrees
- ✓ Systematic periodic photospectrometer absorbance measurements



Acrylic vessels design

Gamma catcher

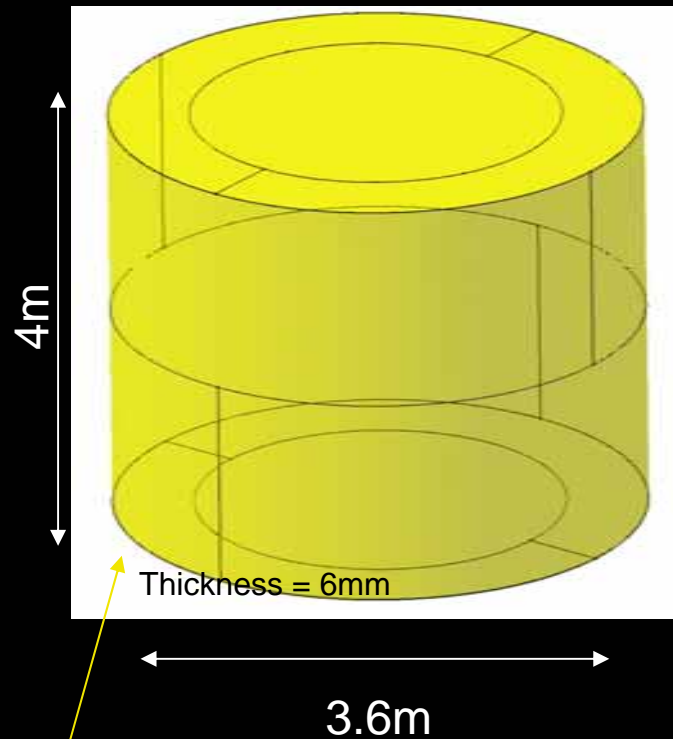

Final assembly (in several part) at Chooz

Target

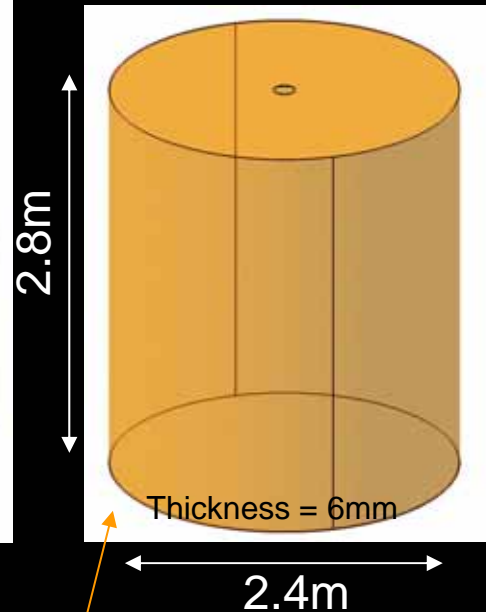

Assembly in the manufacturer workshop

GOAL: 2 Identical cylinders [relative volume]

- 2 inner vessels calibrated at manufactured
- Moved in 1 piece into the detector site

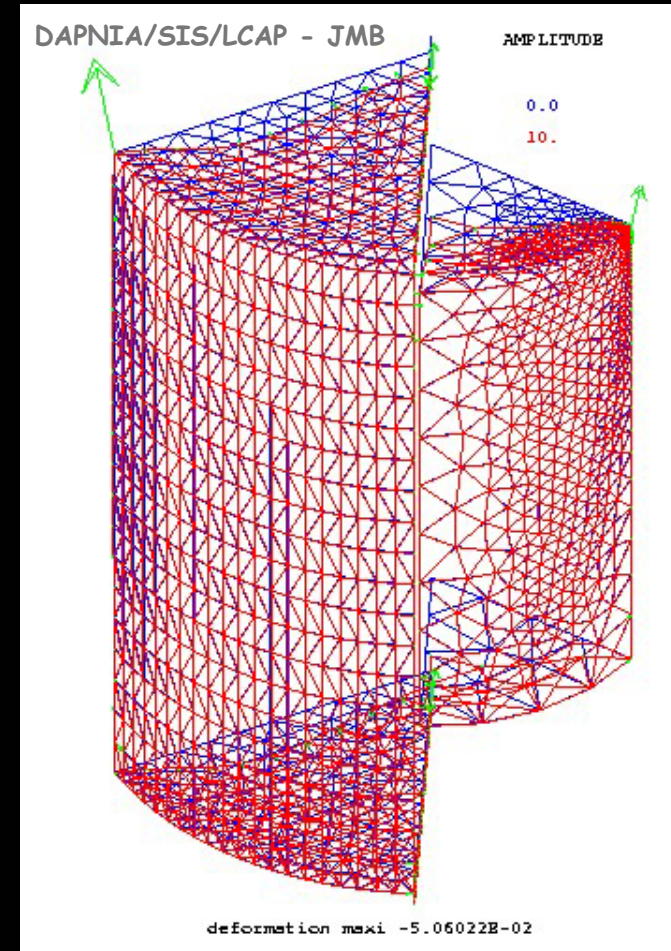

- Suspension: 3 points at 120 degrees
 - Empty weight:
 - Target = 220kg
 - Gamma catcher = 470kg
- Maximum stress: 12 MPa

Double-Chooz sensitivity

- Reactor thermal power: **8.4 GW**
- Near detector distance: **150 meters** Volume N & F: **12.67 m³**
- Far detector distance: **1050 meters**
- Near detector efficiency: **32 %**
50 % dead time x **80 % global load factor** x **80 % detection**
- Far detector efficiency: **64 %**
No dead time x **80 % global load factor** x **80 % detection**

• Standard analysis →
$$\chi^2 = \sum_{A=N,F} \left\{ \sum_i \left[\frac{(T_i^A - O_i^A)^2}{O_i^A + (\sigma_{b2b}^A O_i^A)^2} + \frac{1}{2} \left(\frac{c_i}{\sigma_{shape}} \right)^2 \right] + \left(\frac{b^A}{\sigma_{rel}} \right)^2 \right\} + \left(\frac{a}{\sigma_{abs}} \right)^2 + \left(\frac{d - \Delta m_{13}^2}{\sigma_{\Delta m_{13}^2}} \right)^2$$

absolute	backgrounds
$\sigma_{abs} = 0.02$	$\sigma_{b2b} = 0.01$
relative	$Rate_{bkg} = 0.01$
$\sigma_{rel} = 0.006$	$\sigma_{bkg} = 1.0$

Expected number of events in bin i: $N_i^A (\sin^2(2\theta_{13})_{gen})$

Distortions to theoretical spectrum in O_i^A :

Theoretical prediction : $T_i^A = (1 + a + b^A + c_i) \times N_i^A (\sin^2(2\theta_{13})_{rec})$

Global Normalization Error
Relative Normalization Error
Spectral shape uncertainty
Backgrounds subtraction

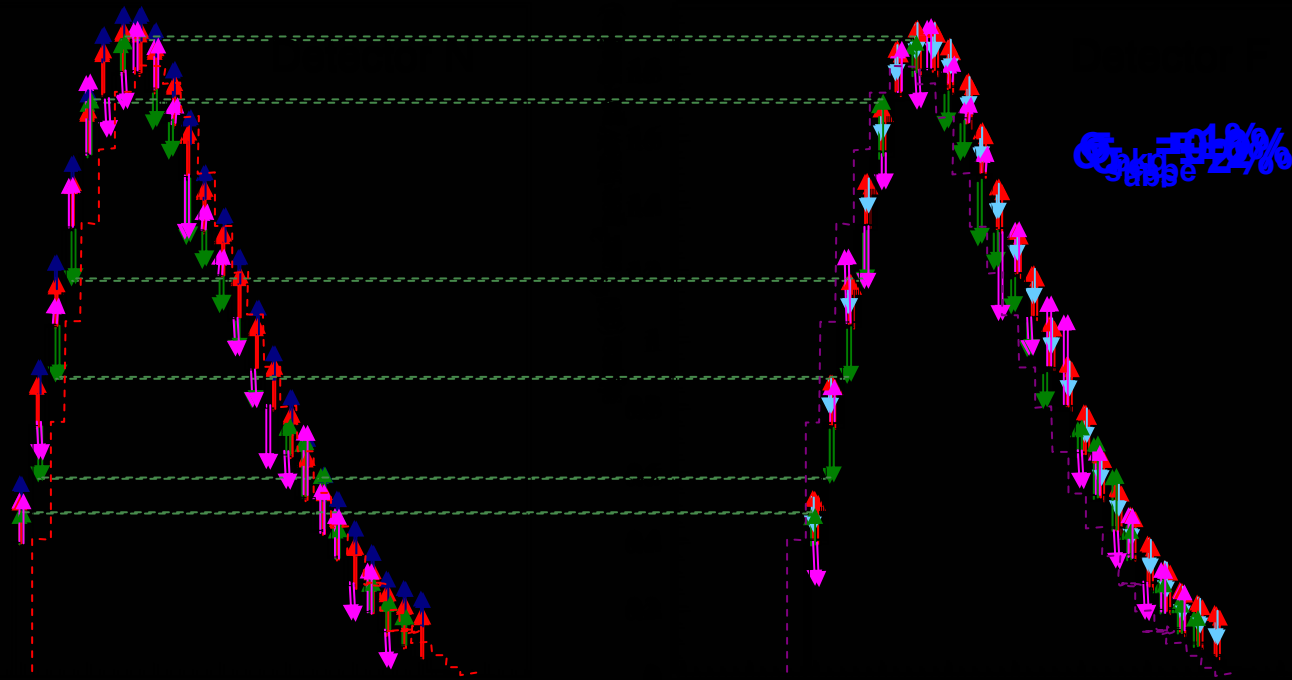

Sensitivity at 90% C.L. if $\sin^2(2\theta_{13})=0$ versus integrated luminosity in RNU

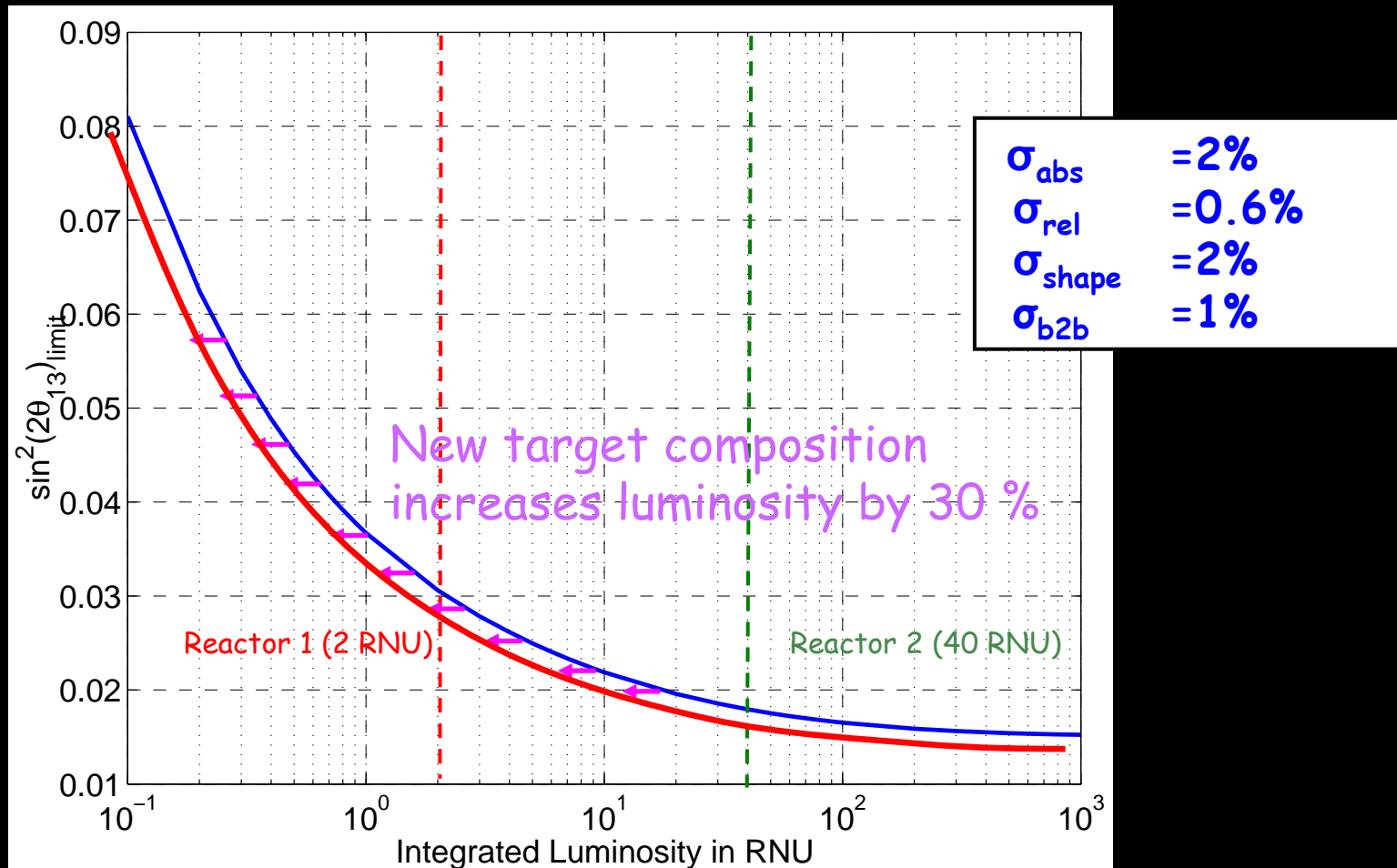

1 RNU = 200 t.GW.y = ~ Double-Chooz 3 years

Summary & outlook @Double-CHOOZ

- ✓ Support for the EDF power company to do a 2nd experiment @CHOOZ
Double-CHOOZ sensitivity: $\sin^2(2\theta_{13}) < \sim 0.03$, 90% C.L. ($\Delta m^2 = 2.0 \cdot 10^{-3} \text{ eV}^2$)
Current limit: CHOOZ : $\sin^2(2\theta_{13}) < 0.2 \rightarrow$ discovery potential !
- ✓ Technology / design well known (CHOOZ, BOREXINO, KamLAND, ...)
 \rightarrow few R&D needed : Gd loading (stability) + material compatibility
- ✓ Proto-collaboration: PCC, Saclay, APC, TUM, MPIK, Tübingen, Kurchatov, Italy
 \rightarrow (maxi-)letter of intent (march 2004) \rightarrow final proposal (+6 months)
- ✓ Scientific committee for approval in France: Saclay, 10/03/04 & CNRS, 29-30/03/04
- ✓ Experiment cost, Double-CHOOZ case:
2 x ~13 tons, preliminary detector cost ~8 Meuros (Civil engineering not included)
- ✓ Goal: construction starts end of 2005 & data taking beginning of 2008

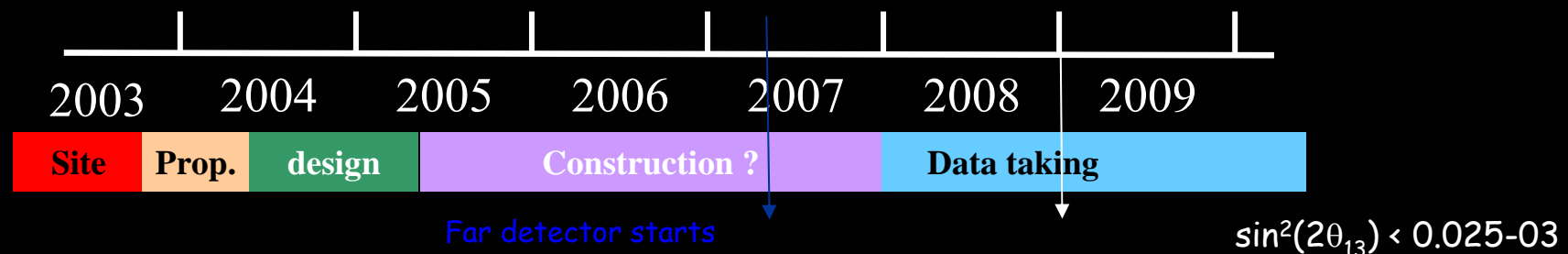

Double-Chooz &



- ✓ IAEA :International Agency for Atomic Energy
- ✓ Missions: Safety & Security, Science & Technology, **Safeguard & Verification**
 - Control that member states do not use civil installations with military goals (production of plutonium !)
 - Control of the nuclear fuel in the whole fuel cycle *
 - Fuel assemblies, rods, containers * (*Anti-neutrinos could play a role!)
 - Distant & unexpected controls of the nuclear installations *
- ✓ Why IAEA is interested to antineutrino ?
 - IAEA wants the « state of the art » methods for the future !
 - Several futuristic methods under study Kr, I, Cs gas trace in atmosphere
 - Cost issue ...
- ✓ IAEA wants a feasibility study on antineutrinos
 - Monitoring of the reactors with a Double-Chooz like detector ?
 - Monitoring a country - new reactors "à la KamLAND"
- ✓ CEA/Saclay → we already ask some support for:
 - Double-Chooz near detector
 - New nuclear physics program to improve knowledge of reactor ν spectrum